

**ATMOZ 2-75**

**VACUUM PACKAGING MACHINE**



Optional without extra costs: 2 seal bars (left-right)

**FEATURES**

- Standard with 2 seal bars (front-back): 2 x 660 mm
- Optional without extra costs: 2 seal bars (left-right)
- Standard double seal (two wires). Optional without extra costs: Cut-off or Wide seal (10 mm)
- Silicone holders easily removable for cleaning and maintenance purposes
- Pump capacity: 160 m<sup>3</sup>/h Busch vacuum pump
- Pump maintenance and cleaning program
- Machine cycle: 15-40 sec
- Standard Digital control with 10 program memory and Time control
- Flat work plate
- Comes with 1 layer of insert plates for a faster cycle and product adjustment
- Stainless steel exterior

**OPTIONS**

- 1-2 Cut-off seal
- Sensor control
- Liquid control
- Gas flush (incl. pressed air connection)
- Soft Air to protect the product and vacuum bag
- ACS

**ACCESSORIES**

- Inclined insert plate
- 2nd layer of insert plates
- Service kit for standard maintenance

**DESCRIPTION**

The robust, stainless steel Atmoz 2-75 vacuum packaging machine has a specific construction of both the lid and the work plate. This results in longer seal bars compared to other series. This double chamber floor model is standard equipped with a Busch vacuum pump and complies with CE standards.



Henkelman offers standard 1 year warranty on the Atmoz-series.

**SEAL BAR CONFIGURATION**

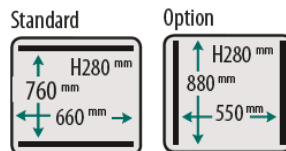

# VACUUM PACAGKING MACHINE ATMOZ 2-75 – SPECS

## VACUUM PACKAGING MACHINE ATMOZ 2-75 – SPEC SHEET

### DIMENSIONS

In mm

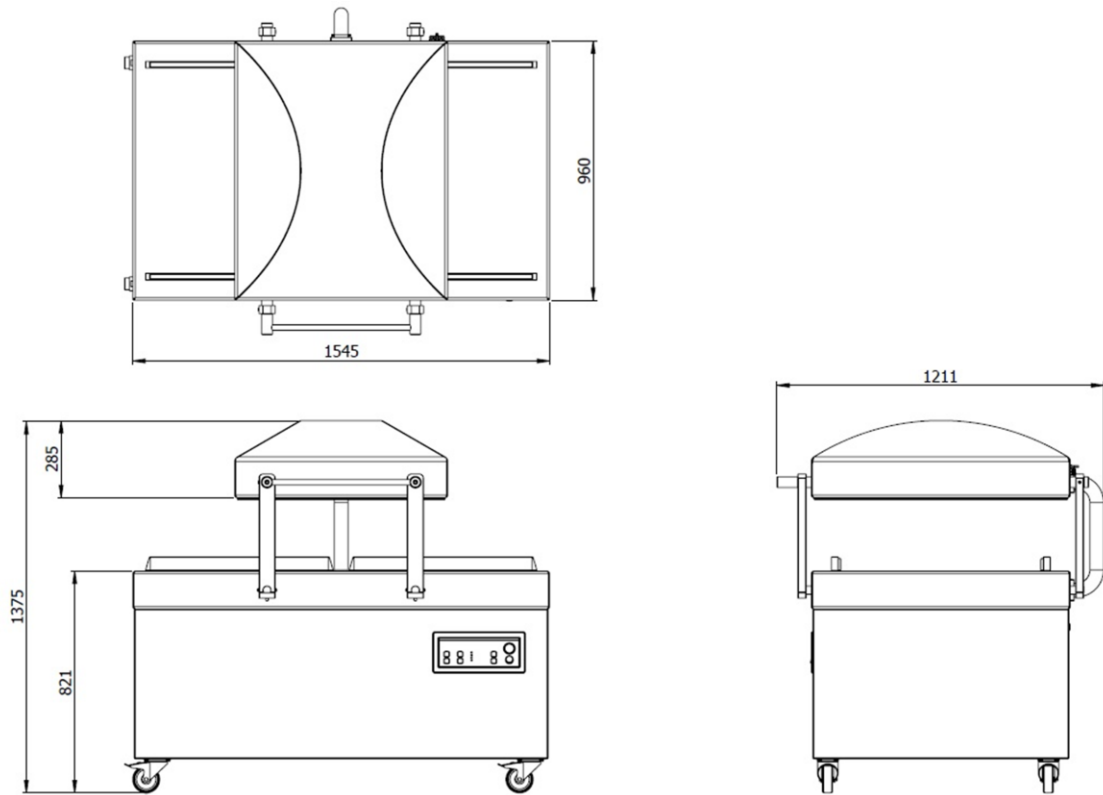

Model	Dimensions (mm)		Voltage* (Hz)	Pump capacity (m <sup>3</sup> /h)	Power (kW)	Weight (kg)
	Chamber (usable space) L x W x H	Machine L x W x H				
Atmoz 2-75	760 x 660 x 280	1211 x 1545 x 1106	400V-3-50	160	2,2 – 4,8	462

\* Other voltages available



**HENKELMAN BV**  
Titaniumlaan 10  
5221 CK 's-Hertogenbosch  
The Netherlands

**Sales support**  
P +31 73 621 36 71  
E [info@henkelman.com](mailto:info@henkelman.com)  
**Service/technical support**  
P +31 73 621 36 71  
E [service@henkelman.com](mailto:service@henkelman.com)